

# MINI FRONT LOADER - N500

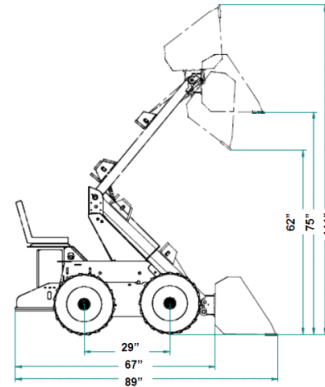
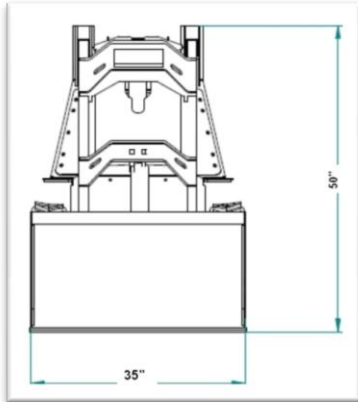

DIMENSION AND WEIGHT		ENGINE	
Operating weight	1588 lbs.	Make/Model	Kohler
Dimensions	35" W.x70" H.x89" L.	Max. RPM	4000 RPM
Ground Clearance	7"	Cylinders	Single
OPERATING INFORMATION		Max. HP	14 HP
Raising Hight	75"	Fuel Consumption	0.6/hr
Max. Bucket Force	661 lbs.	Electrical System	12 V with electric start
Max. Arm Force	992 lbs.	UNDERCARRIAGE	
HYDRAULIC SYSTEM		Traction Motor	Gerotor x 2
System Operating Pressure	2680 PSI	Traction Torque	693 lbs-foot each Side
Pump Type	Gear 1 Stage/2 Stage opt.	Traction Brake	Hydraulic
Flow	4 GPM/8 GPM/2500 RPM-2 Stage	Track Type	Rubber Tracks or Wheels
CAPACITIES		Tire Size	16.5x6.50 - 8
Hydraulic System	4 Gal.	Track Width	7.1"
Fuel Tank	1.6 Gal.	Max. Speed	4 km/hr or 8km/hr for 2 Pumps
Engine Oil	0.4 Gal.	Max. Gradeability	35 deg.

The N500 Mini Front Loader is an irreplaceable piece of equipment for various installations (electrical, gas, water, sewage) as well as for landscaping and general construction. The N500 is designed for the same spectrum of jobs as the bigger front loaders but in a smaller scale. However, due to the smaller scale it is more useful in space limited areas as well as it has a variety of different attachments that can be utilized. The advantages in power, efficiency, versatility and value are driven by our robust features. This product is designed and manufactured in Europe using high quality components.

**The main advantages of the design include:**

- ✓ Light design that requires less horsepower
- ✓ Providing less surface impact and lower operating pressure
- ✓ Compact size that is perfect for space limited areas
- ✓ Low center of gravity ensures an extremely stable operation
- ✓ All sliding joints are sealed and lubricated. This ensures long-term operation of the machine and in case of wear, easy replacement of worn connections with new ones
- ✓ The whole structure is powder coated

**Standard equipment of the Mini Front Loader include:**

- ✓ Hydraulic oil level meter
- ✓ Ground switch
- ✓ Hour meter
- ✓ Audible alarms
- ✓ Quick connectors for additional equipment
- ✓ Hydraulic pressure gauge
- ✓ Hydraulic fluid filter
- ✓ Adjustable seat
- ✓ Hand throttle with speed control located at the driver's seat
- ✓ Standard size bucket – 0.17 cub.yd

**Available attachments:**



*Pallet Forks*



*Standard Size Bucket*



*Hydraulic Plow*



*Gripper with Teeth*